

MH118-2A

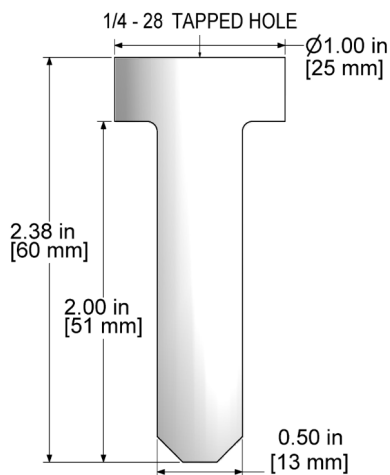

VIBRATION ANALYSIS HARDWARE

Motor Fin Mount Probe Pad, 0.5" x 2.0" (12.7 mm x 50.8 mm) Probe Tip



Product Features

Mounts conveniently between motor cooling fans with use of adhesive

- ▶ Attracts magnetic bases for portable measurements
- ▶ Epoxy Catch side textures
- ▶ Permanently installed with adhesive

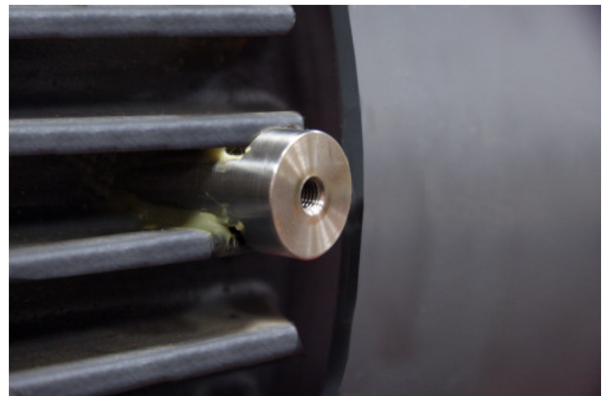

Specifications

Max Temperature	N/A
Case Material	17-4 Stainless Steel
Pull Strength	N/A
Sensor Mounting	1/4-28 Tapped Hole
Field Mounting	Epoxy (Sold Separately)
Recommended Epoxy	CTC MH109-2A Sold Separately
Protective Cover	CTC CP101-2A Red Cap Cover

Chemical Compatibilities for Reference

- ▶ Gasoline - A
- ▶ Methanol - A
- ▶ Lubricants - A

Compatibility

- ▶ Compatible with all sensors with 1/4-28 mounting stud or bolt
- ▶ Conversion mounting studs sold separately

Backed by our Unconditional Lifetime Warranty

Stock Product